

IEC 61850 – More Than Just GOOSE: A Case Study of Modernizing Substations in Namibia

Dorran D. Bekker, *Consolidated Power Projects*
 Peter Diamandis, *Trans-Africa Projects*
 Tim Tibbals, *Schweitzer Engineering Laboratories, Inc.*

Abstract—The need for a unified approach to a substation communications standard that has been addressed by the IEC 61850 standard is well recognized by utilities and vendors alike. The introduction of new paradigms in the approach to substation communications, as well as the foundation provided by modern software development techniques to develop multifunctional devices, has resulted in a standard that is complex to digest and apply. Early adopters of the technology have implemented solutions that do not leverage the full capabilities of the standard and foundational technologies that it is built on. Many systems are poorly specified and often left to vendor turnkey implementation, which may not always be in line with the “spirit” of the standard.

Applying IEC 61850 requires careful consideration of network design, data modeling of devices, data reporting for SCADA (supervisory control and data acquisition) and HMIs (human-machine interfaces), infrastructure management, system testing, and personnel training. This paper discusses the approach taken in the design of an IEC 61850-based substation solution for EHV (extra-high-voltage) and HV (high-voltage) applications in the Namibia power utility, NamPower.

I. INTRODUCTION

Modern electrical substation control rooms follow the trend of information technology data centers where everything is becoming virtualized. The days of dedicated metering, measurements, and control and protection systems are quickly fading. Dedicated physical devices have largely been replaced with modern IEDs (intelligent electronic devices), which are software-based logical devices. Dedicated disturbance recorders, breaker monitoring systems, battery monitors, and transformer monitoring systems are being integrated as yet another logical device in modern IEDs. The process of modernizing secondary equipment in substations has reached the point where even cabling is virtualized in the form of messages over high-speed Ethernet networks. Physical Ethernet networks are also virtualized to represent multiple logical networks.

Using IEDs to communicate with each other over high-speed networks has been the norm in the industrial automation sector for a number of years now. Implementation of field bus networks has brought intelligence down to the simplest of devices, such as actuators and proximity sensors. In a similar fashion to the migration from relay boards to programmable logic controllers, the migration from hard-wired plant interfaces to communications systems has changed the nature of automation systems in industrial applications. The modernization of the substation environment is, of course,

similar in nature to what has happened in the industrial automation sector.

Intelligent devices provide a number of additional benefits that are both tangible and intangible. The ability of the devices to self-diagnose, store sequence of events, and provide asset details and firmware information on request makes previously tedious processes much simpler. From a communications perspective, however, one of the greatest engineering benefits is the self-documenting capability of these devices. The encapsulation of the data model within the device is one of the greatest advantages this technology has to offer.

II. HISTORICAL BACKGROUND

The interfacing of substation control equipment has traditionally been hard-wired. Outputs from one device became the inputs to another device. In many cases, this was how different devices communicated with each other. The only devices that would typically implement a digital message communications standard were the RTUs (remote terminal units), which presented the hard-wired substation information to control centers using a proprietary or standardized SCADA (supervisory control and data acquisition) communications solution. Typical examples of these communications standards include DNP3, IEC 60870-5-101, and IEC 60870-5-104. There have also been numerous attempts at defining a communications interface for substation equipment. Examples include standards such as IEC 60870-5-103 for communicating with protective relays and IEC 60870-5-102 for metering devices. Vendor proprietary solutions have also addressed the need for solutions, such as LONBUS and PROFIBUS. Most of these standards are designed to work over point-to-point serial, EIA-232, or serial bus interfaces, such as EIA-485. The implementation of such communications solutions has typically been aimed at meeting the requirements for SCADA purposes.

III. ETHERNET IN THE SUBSTATION

High-speed communications infrastructure in substations has been needed for a number of years. The evolution of numerical relays, intelligent meters, distance-to-fault locators, and disturbance recorders has made the need to communicate with these devices essential in order to extract the maximum possible benefit from the equipment.

Implementing switched Ethernet technology in the substation environment addresses the challenge of accessing data contained in various IEDs. The enabling factors of modern Ethernet networking technologies for substation applications include:

- High signaling rates: Ethernet supports signaling rates of 10, 100, 1000, or 10000 Mbps (megabits per second) with standard off-the-shelf equipment. The fastest alternatives used in the industrial sector operate at about 10 to 12 Mbps.
- Flexible architecture: Unlike traditional EIA-485 physical bus topologies, Ethernet switches provide a per-packet, circuit-switched mechanism for data flows within the switch. This makes the technology scalable in terms of capacity requirements. In addition, Ethernet switches can be connected together in a number of different topologies, providing further flexibility and scalability. Common switched Ethernet topologies include ring, star, double-star, tiered, and meshed networks.
- Cabling choices: The connection of devices to Ethernet switches and of Ethernet switches to each other is done using point-to-point connections. This provides for the choice of shielded copper cabling or fiber-optic cabling to meet this need. Copper Ethernet cabling uses a dedicated transmit and receive circuit with individual twisted pairs. Fiber-optic communications circuits by default normally consist of a dedicated transmit and receive fiber. This dual circuit provides full-duplex communications that increase the performance of Ethernet technologies.
- Priority tagging: A historical problem with Ethernet is its inability to provide the determinism required for industrial applications. This has been addressed with data priority tagging, per IEEE 802.1p and IEEE 802.1Q [1]. In conjunction with the circuit switching capability of Ethernet, priority tagging has effectively addressed the need for determinism in many applications.
- Cost per port: The cost of embedding Ethernet within devices is becoming cheaper because of the popularity of the technology across all industry sectors. Vendors of substation secondary equipment have provided Ethernet interfaces with their devices for years.
- Substation-grade Ethernet devices: IEC 61850 specifies that communications equipment meet the same requirements as protection and control IEDs.

In order to take advantage of Ethernet networks in the substation, the DNP Users Group developed a solution that allows DNP3 to take advantage of the benefits offered by TCP/IP (Transmission Control Protocol/Internet Protocol) for both local- and wide-area networks. However, DNP3 is largely used for SCADA purposes.

The EPRI (Electric Power Research Institute) UCA2 (Utility Communications Architecture) project proved that Ethernet technology can be used for SCADA communication and is also capable of meeting the communications requirements for other devices within the substation [2]. In fact, the project proved that the Ethernet

communications infrastructure can reliably replace hard-wired communications interfaces between devices, including time-sensitive signaling related to tripping, provided the network is well designed.

The success of the UCA2 project spurred the development of the IEC 61850 standard, which is built on the findings of the project. Interdevice communication over Ethernet networks is described within the standard, which also places great emphasis on the data model that needs to be applied across all devices that wish to communicate using the standard. The primary purpose of the data model is to unambiguously define the representation of data elements present in a substation environment and the relationship between these data elements.

IV. NETWORK ARCHITECTURE

The design of the network architecture for NamPower projects comprises a switched Ethernet topology that uses a double-star backbone and edge switch design, as shown in Fig. 1. The design was selected because of its performance characteristics and inherent enhanced redundancy options. The design is also scalable and allows for extension without impacting system operation or otherwise compromising its redundancy. A redundant device connection to the network was not a requirement for the project, because this aspect is not conclusively addressed in the first edition of the IEC 61850 standard. In addition, various redundancy methods being standardized within IEC 61850 vary significantly in the IED and network architecture requirements. For this project, only the bus zone relays were connected redundantly to two separate switches.

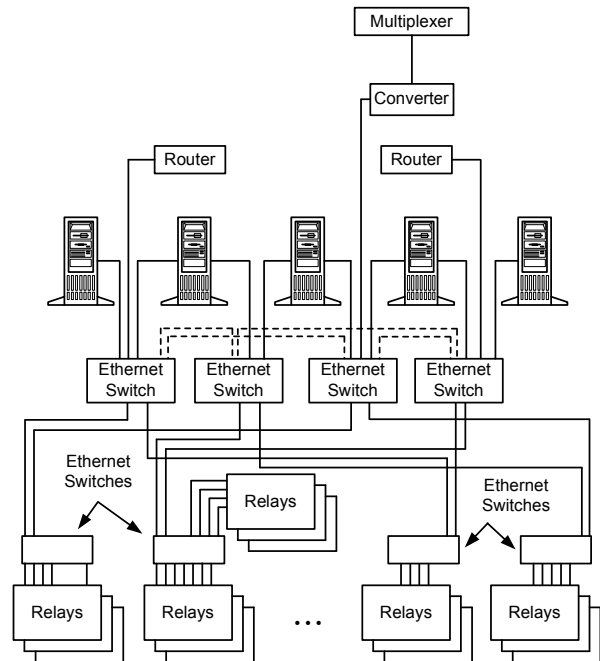

Fig. 1. NamPower network architecture example.

A major design requirement of the network was to allow for flexibility when applying future technologies to the substation without impacting the real-time performance requirements of the network. In order to facilitate this requirement, extensive use was made of VLANs (virtual

local-area networks) and priority tagging for time-critical GOOSE (Generic Object-Oriented Substation Event) messaging. This design approach allows for the incorporation of enabling technologies, such as IP (Internet Protocol) telephony, to use the same network infrastructure without impacting the performance of the protection and control functionality.

V. DEVICE DATA MODELING

IEC 61850 places significant emphasis on data modeling. The standard builds up complex data structures from simpler data types in order to describe substation functions and equipment in a standardized way. Types of equipment, such as circuit breakers, transformers, tap changers, earth switches, and cooling systems, are described by the standard using object-oriented techniques. The IEC 61850 standardized naming convention is applied to the device application definition (known as a logical device) and individual application function descriptions (known as logical nodes). Logical nodes used to define the data models related to protection functions for instantaneous overcurrent also exist, including timed overcurrent, distance, and protection-related functions, such as autoreclosing.

The standard therefore defines a consistent way of describing the information related to a significant number of system functions and substation devices and equipment, but it is not feasible to define every possible logical node. In order to cater to unmodeled or generic substation information, we can use either a generic I/O logical node, known as a GGIO, or extend the standard by defining custom logical nodes and data types. The problem with GGIO logical nodes is that they have little or no semantic relationship to the information being described, and the definition of custom logical nodes cannot be realized on all products.

The process of defining a data model for a substation application requires flexibility within devices, allowing the data model to be defined within the device ICD (IED capability description) file and mapped accordingly to the internal data references of the device. Vendors supporting this level of flexibility within their products make the application of the end user substation model possible without confining the user to predefined models.

Per the guidelines of the standard, Fig. 2 shows the extension of the standard XCBR (circuit breaker) logical node for adding more data objects. This is then described using the IEC 61850 SCL (Substation Configuration Language) within the ICD file for the IED and mapped to the appropriate hard-wired inputs and outputs.

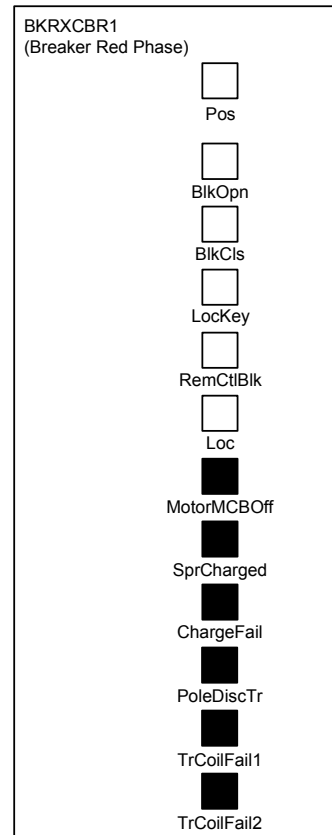

Fig. 2. Extended XCBR logical node.

Fig. 3 shows the use of multiple XCBR logical nodes (one for each phase) and the SIMG (gas insulation supervision) logical node within the same logical device in an IED with the corresponding mapping to a data set to be transported using GOOSE. Describing the model and signal mapping in a diagram greatly simplifies the configuration process and provides suitable documentation for later fault finding and troubleshooting.

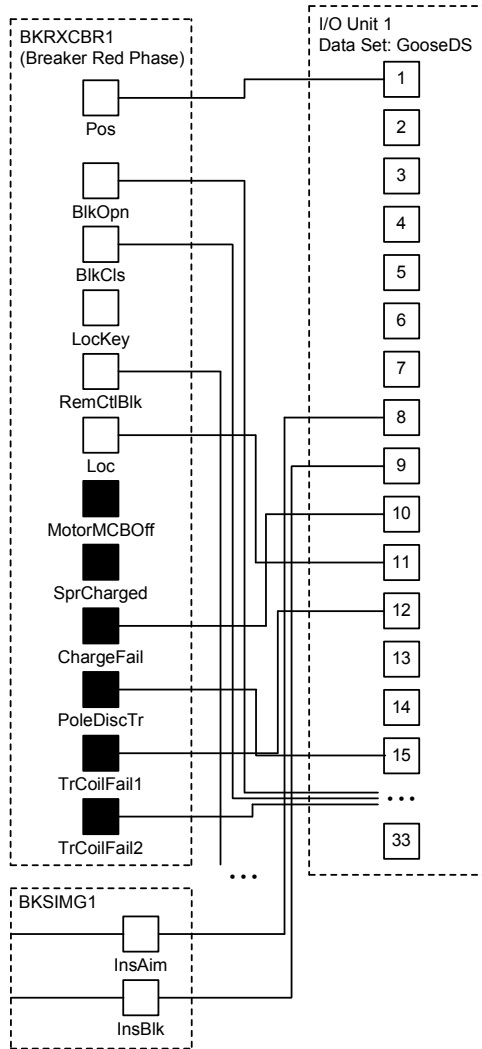

Fig. 3. XCBR and SIMG logical nodes with GOOSE data set.

Fig. 4 shows the definition of a new logical node that maps the signals contained within a substation yard junction box. Again, the definition was completed following the guidelines of IEC 61850-7-4 Appendix A.

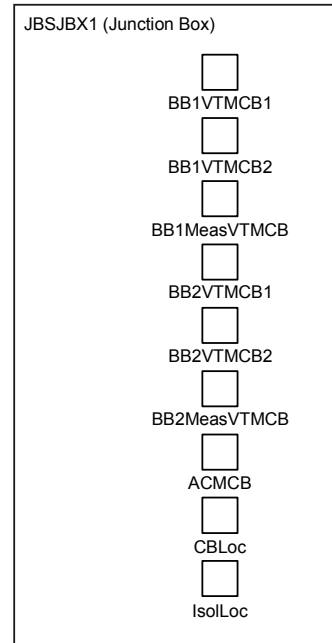

Fig. 4. Custom junction box logical node.

One of the more beneficial aspects of data modeling is that, once modeled, a system easily flows from concept to implementation. A complete model does not easily allow anything to slip through the cracks. It makes testing faster and easier, because the engineer already has a detailed overview to test against, whether it is a small part of the system or some section that comprises all key aspects of the system. It is always much easier to change a model than an implemented system. In other words, data modeling encourages engineers to plan properly.

VI. SUBSTATION AUTOMATION

In the past, if a protection signal from one device was needed in a distant device or in a device in a different building, wiring had to be installed, especially in the case of on-site modifications. This put limitations on device-to-device signaling and substation-wide automation.

For example, as illustrated in Fig. 5, if a signal was needed on multiple devices, either the sending device would need a contact per the receiving device or the contact itself would need to be multiplied or cascaded in order to be connected to all receiving devices. Either in series or in parallel, each of these solutions presents difficulties.

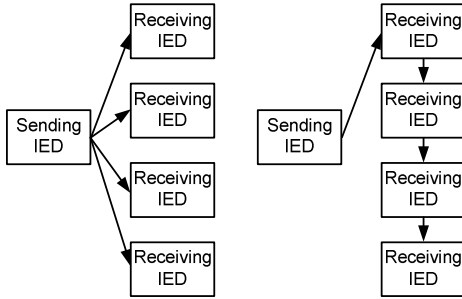

Fig. 5. Hard-wired interdevice signaling.

Devices connected via Ethernet networks allow all devices to be interconnected, sometimes spanning many kilometers. This connectivity provides almost unlimited device-to-device signaling. A single IEC 61850 GOOSE message transmission using multicast addressing allows concurrent reception by numerous devices on the same Ethernet subnetwork, shown in Fig. 6, while meeting the timing requirements for protection applications.

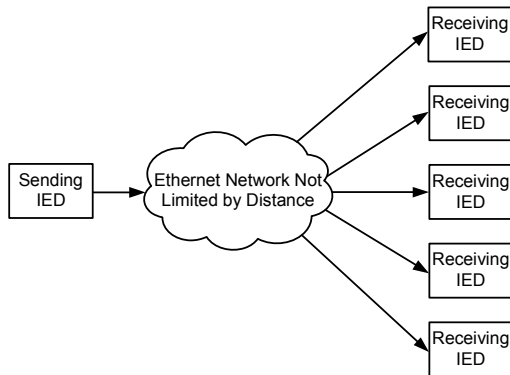

Fig. 6. Multicast messaging.

In addition, the flexibility provided by the standard for peer-to-peer signaling allows for substation-wide automation to provide functions and procedures that can eliminate human error. Automated switching procedures, such as live bus changeover and placing a feeder on transfer, can be implemented, allowing the IEDs to automatically and safely complete complex and dangerous switching procedures every time without error.

VII. SYSTEM MANAGEMENT

A. Network Monitoring and Management

The Ethernet network is a crucial part of the overall system and needs to be monitored. Fortunately, monitoring and management technology for Ethernet networks has existed for many years. Many different forms of monitoring and

management strategies and tools exist, such as SNMP (Simple Network Management Protocol). This allows for a clear, present overview of the system and how it is performing. These tools and technologies lead to simpler and faster maintenance, because the system can be monitored and tested while live. There is no need to shut down the system to perform tests. Furthermore, integration of the SNMP functionality into the gateways and HMIs (human-machine interfaces) allows network monitoring to be presented to control centers via SCADA.

B. Configuration Management

Configuration management always plays a major role in the successful implementation of any system. Because IEC 61850 stores its configuration in an open format (ICD, CID [configured IED description], and SCD [system configuration description] files use industry standard XML [Extensible Markup Language]), it is easy to integrate the configuration into existing configuration management systems already being used by engineers. Configuration information is thus readily and easily obtained. Many tools exist to take XML configuration files and perform configuration revision (also built into IEC 61850), alterations, storage, distribution, and many more functions used by engineers.

C. Documentation

Detailed and substantial documentation can easily be generated by combining all of the tools mentioned in Section VII, Subsection B. IEC 61850 can even store some documenting details inside the configurations itself. All of this documentation helps engineers understand, troubleshoot, and train on new systems.

VIII. SIMULATION AND TESTING

GOOSE messaging can make testing and simulation much easier than before. GOOSE tools give an engineer the ability to monitor or reproduce any GOOSE message. This can be done using a laptop (as shown in Fig. 7), turning it into a powerful simulation and monitoring tool.

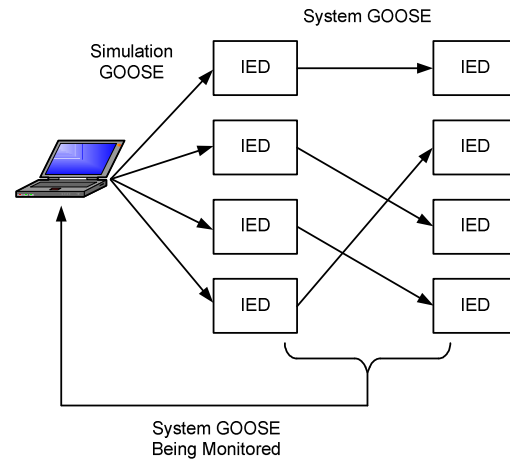

Fig. 7. Laptop sending simulation GOOSE messages and monitoring system GOOSE messages.

A laptop can be used to set up complicated automated testing by sending GOOSE messages to the system and monitoring the results via GOOSE messages or MMS

(Manufacturing Message Specification) reports, depending on the particular system configuration. This helps tremendously with testing and engineering time, because there are no temporary wired signals to be set up and wired into the system. The other important advantage of virtual testing is that large substation-wide testing can be done, such as breaker fail trip, during a substation-wide automated feeder-on-transfer sequence.

IX. IMPLICATIONS

So what do all of these new technologies and concepts mean? As mentioned before, Ethernet networks have been around for years and used all over the world in many different forms because of their flexibility, reliability, and speed. Full-time monitoring of all communication is possible. This, coupled with GOOSE messaging, allows engineers to know when their wire is broken in advance rather than having to test for it. This monitoring is available for the relays to use; thus different steps can be put in place to allow for extra flexibility and safety.

IEC 61850 can provide time savings for project and system design, implementation, test, and documentation, all of which impact the bottom line—project cost. Flexible solutions allow for fast scalability of substations, fast integration with existing equipment, and easier adaptation for future applications. Therefore, we can do more with what we have rather than continuously purchasing more equipment.

One of the main implications of an IEC 61850 substation is information distribution. In the past, any signal that was needed by another bay or substation had to be hard-wired if it was to be protection-level secure. By using GOOSE messaging, this same connectivity is achieved via the Ethernet network. The additional benefit is that the same data are available for any relay on the same subnetwork to use without additional wiring. Deciding which applications need information is the only requirement. This capability brings with it an ease of adapting to change or providing solutions to problems that were unforeseen.

X. CONCERNS AND RESOLUTIONS

Numerous concerns related to the IEC 61850 standard have been raised since the standard was published. Most of these concerns are either caused by false assumptions or a misunderstanding of the underlying technologies. Some of the concerns that were addressed during this project include:

- *Tripping times and general signaling between devices are significantly faster with hard wires than with GOOSE messaging.*

This concern proved to be false, and repeated tests highlighted a consistently faster or at least equivalent signaling time achievable using GOOSE messaging. The GOOSE protocol message definition is such that the GOOSE application layer is transported directly using the Ethernet data link layer, thereby eliminating the need to process additional communications layers within the IED firmware.

- *Network congestion can cause delays in the delivery of GOOSE messages.*

This concern is valid only when the features provided by Ethernet technologies are not fully leveraged. Ethernet provides a prioritization scheme and a traffic isolation mechanism by means of VLANs (as defined by IEEE 802.1Q). Hence, a correctly designed Ethernet network can effectively eliminate this perceived risk.

- *Many GOOSE messages on the network can overload the IED CPU (central processing unit) with unnecessary processing of GOOSE messages.*
- The IED filters GOOSE messages based on the destination multicast address, and further filtering is possible by the network switches using VLAN tags embedded within the Ethernet frame of the GOOSE message. Unique destination multicast addresses and carefully designed VLAN filtering are therefore essential on large networks.

- *The entire system fails when a network failure occurs.*

A redundant network design is very effective in addressing this failure concern. Many utilities apply a redundancy philosophy that can also be extended to the substation-switched Ethernet network. This project made use of redundant backbone switches with redundant connections from the bay switches to the backbone switches. The bus zone IEDs also used the redundant connections in two separate network switches. Should the highly unlikely catastrophic condition arise where the substation network is rendered unavailable, the protection will still operate, because all instrument transformer inputs and trip coil outputs are wired directly to the protection IEDs.

- *What if the GOOSE message is not sent or is corrupted in transit?*
GOOSE messages are constantly sent by transmitting IEDs and may contain the value of several signals, as defined by a data set. Any signal change within a data set speeds up transmission repetition of the GOOSE messages so that the risk of reception failure (because of a corrupt or lost message) is reduced. The reception of GOOSE messages is constantly monitored by associated IEDs, and failure of such reception of any GOOSE message must be suitably alarmed. In addition, a contingency plan must be made within the IED protection and automation logic to change behavior from communications-aided logic to noncommunications-aided logic when GOOSE reception fails.
- *How can I test the virtual wiring of GOOSE messages?*
Physical I/O wiring was replaced with virtual wiring of GOOSE messages communicated between IEDs, but the resulting testable condition remains the same. Is the trip transmitted between IED 1 and IED 2? Does the interlock indicate and function as designed? These are all testable conditions via logic or actual physical operations in an IED. IEDs, test equipment, and software are capable of easily monitoring GOOSE messages, the resulting logic, or the indications resulting from the receipt of GOOSE data. The engineer tool set now includes more network monitoring equipment and software.

XI. TRAINING

The issue of staff expertise with the new technology is often raised as an entrance barrier to IEC 61850 and networking technologies. Many utilities see the technology learning curve as being too high, thus making successful implementation risky.

There is definitely a different skill set required when implementing Ethernet networks and an IEC 61850-based solution. Switched Ethernet networking, data modeling, and new troubleshooting techniques present additional layers of complexity and introduce an additional learning curve to staff not familiar with these technologies.

However, dealing with technological innovations and the evolution of solutions is not new to the energy industry. Utility staff have had to familiarize themselves in the past with the migration from electromechanical to solid state and then to numerical relays. This includes understanding SCADA protocols and related communications issues, the increasing intelligence of multifunctional devices, and the natural blurring of previously clear lines of responsibility. Continuous professional development is a key success factor in any industry.

XII. CONCLUSION

Implementing a comprehensively engineered IEC 61850 solution is not a trivial task. Training is a primary issue that must be addressed, because the change in thinking is more revolutionary than evolutionary. Ethernet networks and multifunctional devices blur the distinctions between

protection, control, measurements, metering, dc systems, transformer monitoring, disturbance recording, system testing, and most other aspects of the substation environment.

The long-term success of modern substation projects hinges on planning for current technologies and designing for the future. Building substation networks that scale and support devices, such as synchrophasors, merging units and other process bus components, and IP telephony, should be a core consideration of modern system designs. Further success factors include the application of IEC 61850 modeling techniques on a system-wide basis. All equipment vendors should provide flexible devices without compromising functionality.

Finally, the engineering time associated with modern projects should not be underestimated. The potential benefits of IEC 61850 technology in terms of reduced engineering and commissioning times can only be truly experienced once the correct levels of familiarity and experience with the standard and supporting technologies have been gained. However, once this has been achieved, benefits can be realized throughout all aspects of a project. In summary, such projects may not be simple, but they are achievable and certainly worthwhile.

XIII. REFERENCES

- [1] IEEE Standards for Local and Metropolitan Area Networks—Virtual Bridged Local Area Networks, IEEE Standard 802.1Q-2005.
- [2] UCA2.0 Standard Document, Part 1, Electric Power Research Institute (EPRI), Palo Alto, CA. Available: <http://my.epri.com>.

XIV. BIOGRAPHIES

Dorran D. Bekker received his BSCE in 2007. After working at e-LEK Engineering as an application engineer for a year, he joined Consolidated Power Projects as a SCADA/automation engineer.

Peter Diamandis received his BSEE from the University of the Witwatersrand in Johannesburg, South Africa, in 1991. Currently, he is an independent consultant, formerly of Eskom, working for Trans-Africa Projects.

Tim Tibbals received his BS in electronics engineering from Gonzaga University in 1989. After graduation, he joined Schweitzer Engineering Laboratories, Inc. (SEL) as an application engineer, performing system studies and relay testing. He has also worked as a development engineer and as part of the development team for many of the communications features and functions of SEL products. He subsequently worked as an application engineer for protection, integration, and automation products, assisting customers through product training, seminars, and phone support. He served as the automation services supervisor in the SEL systems and services division for several years before returning to the research and development division as a product engineer for automation and communications engineering products. He is currently a senior automation system engineer in the sales and customer service division.